

Metals Manufacturing Products

Cool-Cast Nozzles

Product Guide

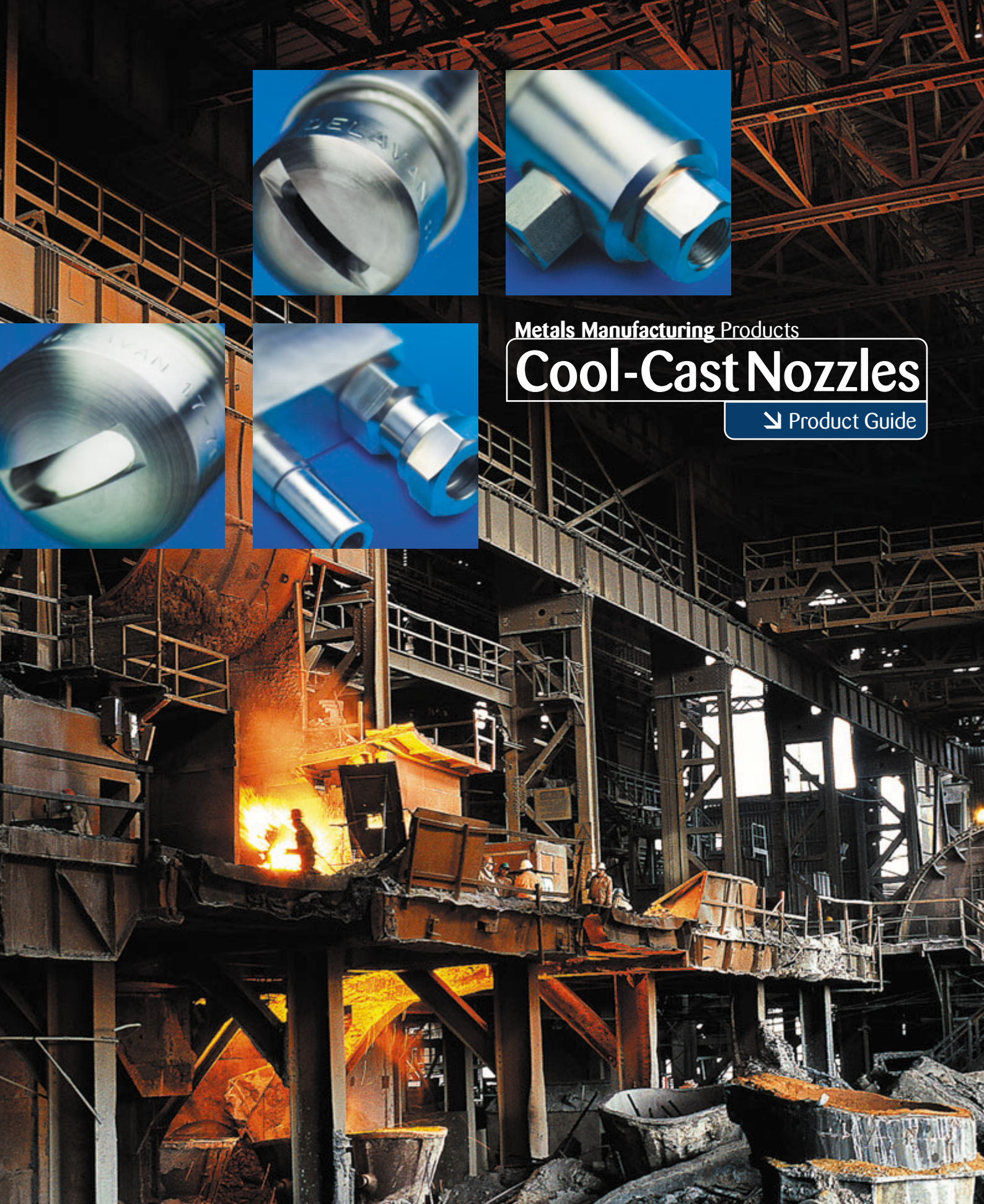

Cool-Cast Product Introduction

Cool-Cast Nozzles



Delavan Spray Technologies Continually meeting the challenges of new industries and markets

Delavan Spray Technologies, part of Goodrich Corporation, is a world leader in the design and manufacture of high quality spray nozzles and fluid handling systems. Since the company was founded back in 1935, the Delavan name has always stood for quality, flexibility and reliability.

The continuous casting of metals is a relatively new process in the steel industry, but tremendous strides in development have been made in recent years. In the constant pursuit of technological advancements, **Delavan's** engineering staff have worked with steel mills world-wide to implement many improvements in the casting process.

Better Cooling With Less Water

The result of much research and development is the **Delavan Cool-Cast** nozzle, which with its tightly uniform droplet size can significantly improve slab quality and reduce energy costs in your continuous casting operation. The table below provides an illustration of the typical droplet sizes.

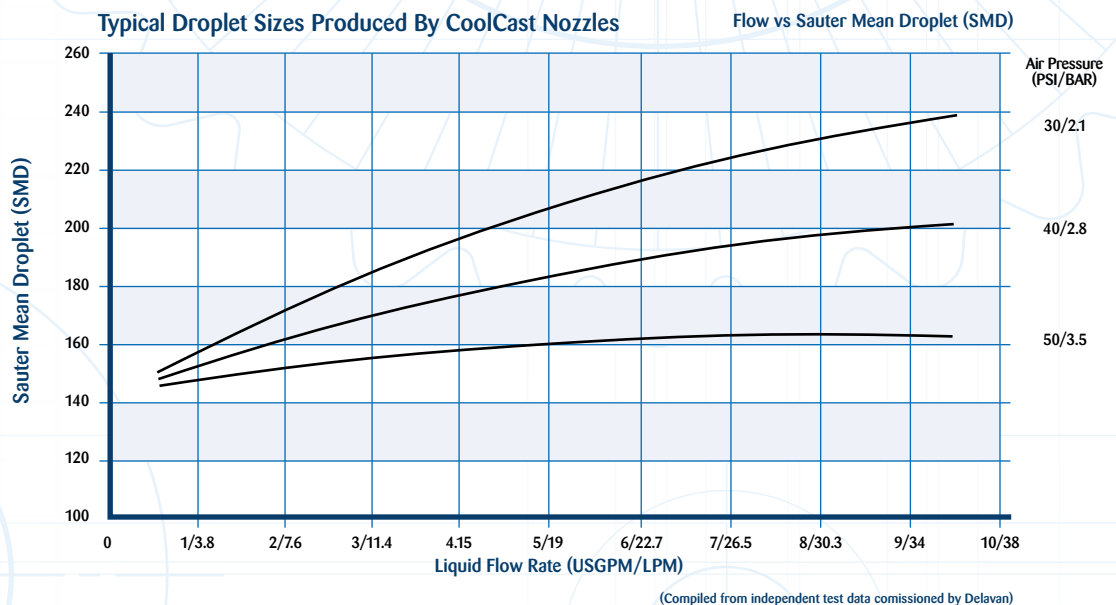

Producing steel in today's market from slabs to bar mills including secondary cooling during the casting process requires efficient spray nozzles. **Delavan's** newest 'Block Style' **Cool-Cast** nozzle offers flexibility in alignment for tight space in-between the framed segments. The ability to use quick connect couplings with the parallel piping gives operators access to quick release nozzles during rebuilds. With interchangeable components, liquid and air can be easily adjusted to meet product changes for various grades of products. The all stainless steel construction extends the durability and life of the nozzle in harsh environments. Typically **Cool-Cast** nozzles produce results using less air than other types, further reducing cost of ownership. The 'Block Style' **Cool-Cast** nozzle has different thread sizes and liquid connections to avoid misalignment.

Our specialist design teams can also provide customised designs for your own applications, contact our sales team on +44 (0)151 424 6821 or inside USA Toll Free: 1-800 Delavan for more information.

Cool-Cast Nozzles

Cool-Cast Spray Characteristics

The patented nozzle design (US Patent 6036116) produces a spray pattern with highly uniform droplets. This makes the cooling process more controllable, with reduced tendency for water puddling and localized uneven cooling or thermally induced roller deflection. The flat spray pattern is thick, even over angles from 60° to 120°, offering good coverage with few nozzles.

The Cool-Cast design consumes less air than conventional nozzles, which saves energy usage through reduced air compressor load.

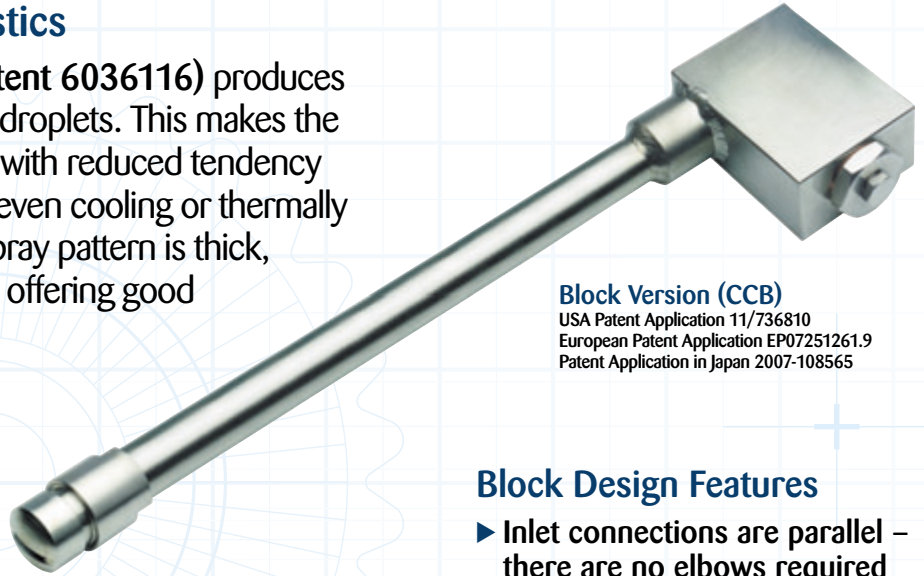

Block Version (CCB)
 USA Patent Application 11/736810
 European Patent Application EP07251261.9
 Patent Application in Japan 2007-108565

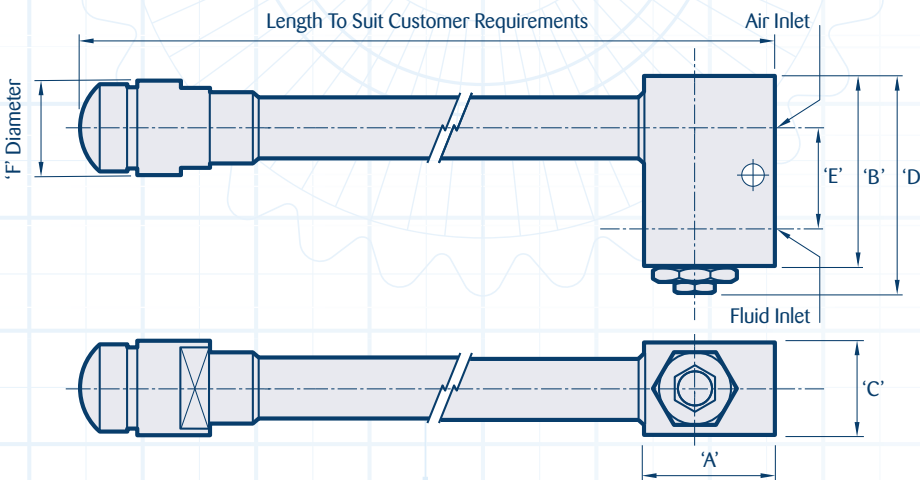

Block Design Features

- ▶ Inlet connections are parallel – there are no elbows required for product installation
- ▶ Easier maintenance – nozzles always go back into original installation, no re-alignment is necessary
- ▶ Fluid orifice can be removed and cleaned/replaced without removing nozzle assembly
- ▶ More robust – less joints
- ▶ Easier installation
- ▶ Patented fluid inlet can permit larger orifice sizes for equivalent flow rates

Block Version Nozzle Assembly Dimensions (inches/mm)

Dimension	Nozzle Sizes											
	2/7.6	2.5/9.5	3/11.4	4/15	5/19	6.5/24.6	8/30.3	9/34	10/38	12/45.5	15/56	17/64.4
A	1.97/50	1.97/50	1.97/50	1.97/50	1.97/50	1.97/50	1.97/50	1.97/50	2.25/57.2	2.25/57.2	2.25/57.2	2.25/57.2
B	2.72/69	2.72/69	2.72/69	2.72/69	2.72/69	2.72/69	2.72/69	2.72/69	2.93/74.4	2.93/74.4	2.93/74.4	2.93/74.4
C	1.18/30	1.18/30	1.18/30	1.18/30	1.18/30	1.18/30	1.18/30	1.18/30	1.57/40	1.57/40	1.57/40	1.57/40
D	3.16/80.2	3.16/80.2	3.16/80.2	3.16/80.2	3.16/80.2	3.16/80.2	3.16/80.2	3.16/80.2	3.4/86.4	3.4/86.4	3.4/86.4	3.4/86.4
E*	1.75/44.5	1.75/44.5	1.75/44.5	1.75/44.5	1.75/44.5	1.75/44.5	1.75/44.5	1.75/44.5	1.75/44.5	1.75/44.5	1.75/44.5	1.75/44.5
F	1/25.4	1/25.4	1/25.4	1/25.4	1/25.4	1.13/28.7	1.13/28.7	1.13/28.7	1.38/35	1.38/35	1.63/41.3	1.63/41.3

Block Version Thread Sizes (NPSC or BSPP)

	Nozzle Sizes											
	2/7.6	2.5/9.5	3/11.4	4/15	5/19	6.5/24.6	8/30.3	9/34	10/38	12/45.5	15/56	17/64.4
Liquid Inlet	3/8"	3/8"	3/8"	3/8"	3/8"	3/8"	3/8"	3/8"	1/2"	1/2"	1/2"	1/2"
Air Inlet	1/2"	1/2"	1/2"	1/2"	1/2"	1/2"	1/2"	1/2"	3/4"	3/4"	3/4"	3/4"

*Pipe centres can be adjusted to suit customer's existing installation.

The original round design of the Cool-Cast nozzle has a lower initial capital cost than the block design, yet still provides the same outstanding spray cooling performance and operational characteristics of the Block version.

A full range of nozzles in different sizes are available for both assembly types and figures are available further in this brochure showing the relevant air consumption and liquid flow rates at a range of air and liquid pressures.

Data contained in this brochure is for guidance only. Normal manufacturing tolerances are +/- 5%.

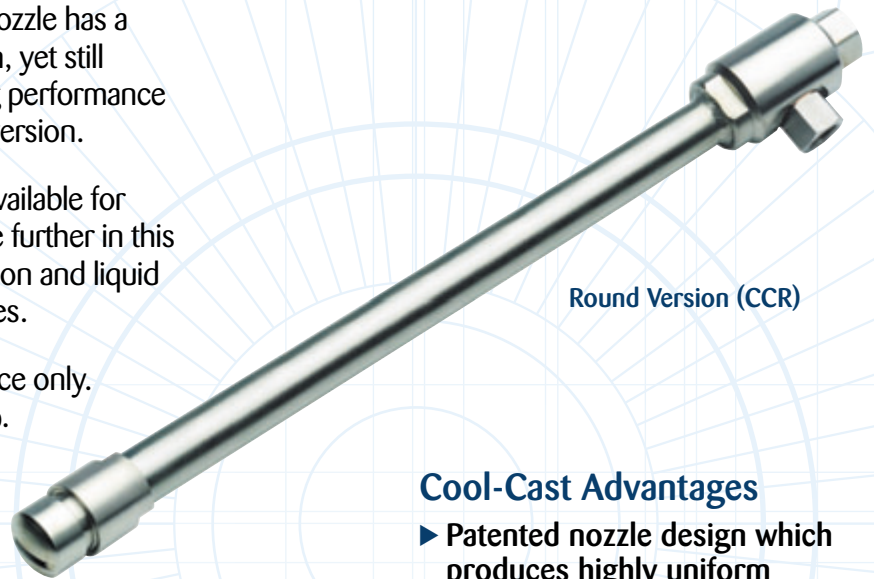

Round Version (CCR)

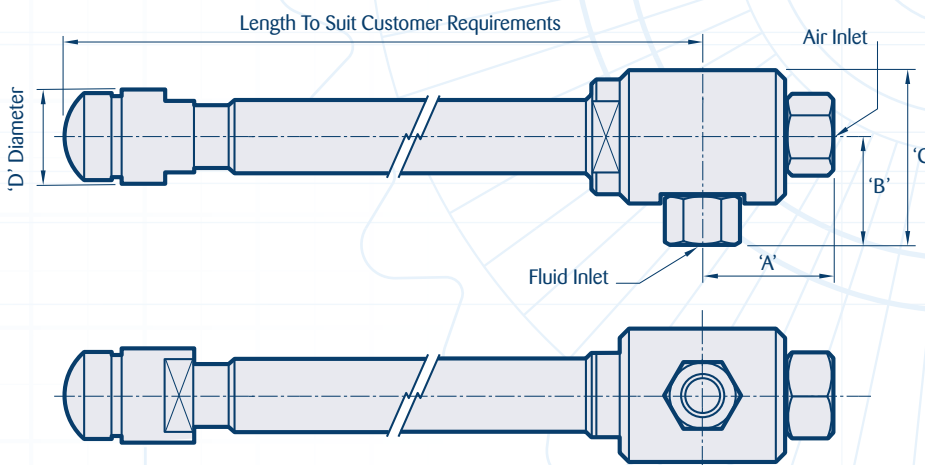

Cool-Cast Advantages

- ▶ Patented nozzle design which produces highly uniform droplets with constant surface area per given spray volume
- ▶ More controllable and even cooling characteristics
- ▶ Reduced air consumption, saving energy through reduced air compressor load
- ▶ Wide passages prevent plugging
- ▶ Maximum heat transfer
- ▶ Large turn-down ratio
- ▶ Constant spray angle over wide pressure range

Round Version Nozzle Assembly Dimensions (inches/mm)

Dimension	Nozzle Sizes											
	2/7.6	2.5/9.5	3/11.4	4/15	5/19	6.5/24.6	8/30.3	9/34	10/38	12/45.5	15/56	17/64.4
A	1.66/42.2	1.66/42.2	1.66/42.2	1.66/42.2	1.66/42.2	1.66/42.2	1.66/42.2	1.66/42.2	2.04/51.8	2.04/51.8	2.04/51.8	2.04/51.8
B	1.38/35.1	1.38/35.1	1.38/35.1	1.38/35.1	1.38/35.1	1.38/35.1	1.38/35.1	1.38/35.1	1.68/42.7	1.68/42.7	1.68/42.7	1.68/42.7
C	2.19/55.7	2.19/55.7	2.19/55.7	2.19/55.7	2.19/55.7	2.19/55.7	2.19/55.7	2.19/55.7	2.68/68.1	2.68/68.1	2.68/68.1	2.68/68.1
D	1/25.4	1/25.4	1/25.4	1/25.4	1/25.4	1.13/28.7	1.13/28.7	1.13/28.7	1.38/35	1.38/35	1.63/41.3	1.63/41.3

Round Version Thread Sizes (NPSC or BSPP)

	Nozzle Sizes											
	2/7.6	2.5/9.5	3/11.4	4/15	5/19	6.5/24.6	8/30.3	9/34	10/38	12/45.5	15/56	17/64.4
Liquid Inlet	3/8"	3/8"	3/8"	3/8"	3/8"	3/8"	3/8"	3/8"	1/2"	1/2"	1/2"	1/2"
Air Inlet	3/8"	3/8"	3/8"	3/8"	3/8"	3/8"	3/8"	3/8"	1/2"	1/2"	1/2"	1/2"

Contact our Helpline or your local distributor for further information
Tel: +44 (151) 424 6821 or inside USA Toll Free: 1-800 Delavan
E-mail: delavanspray@goodrich.com or sales@delavan.co.uk

Cool-Cast Nozzles

How To Select A Nozzle

Below is a table showing the various options available to help when deciding which nozzle is right for your application. On the following pages are capacity charts showing the relevant air consumption and liquid flow rates at a range of air and liquid pressures corresponding to the flow rates shown below. Please be aware that the data in the charts shown on pages 7-9 was generated on Delavan test equipment. Actual figures may differ due to the effects of the local installation.

Cool-Cast Nozzle Selection Chart

Connection Size/Model			Tip Size/Spray Angle						Nozzle Length
Block Version LIQUID AIR	Round Version LIQUID/AIR		Nozzle REF NO.	Flow Rate USGPM LPM		Nominal Orifice Diameter* AIR LIQUID		Standard Spray Angles	Length (Straight)**
3/8" 1/2"	3/8"		2	2 6.7		0.098" 0.098"		50, 60, 70, 80, 90, 95, 100, 110, 120	90-1000mm
3/8" 1/2"	3/8"		2.5	2.5 9.5		0.106" 0.102"		50, 60, 70, 80, 90, 95, 100, 110, 120	90-1000mm
3/8" 1/2"	3/8"		3	3 11.4		0.110" 0.110"		50, 60, 70, 80, 90, 95, 100, 110, 120	90-1000mm
3/8" 1/2"	3/8"		4	4 15		0.134" 0.130"		50, 60, 70, 80, 90, 95, 100, 110, 120	90-1000mm
3/8" 1/2"	3/8"		5	5 19		0.150" 0.146"		50, 60, 70, 80, 90, 95, 100, 110, 120	90-1000mm
3/8" 1/2"	3/8"		6.5	6.5 24.6		0.185" 0.161"		50, 60, 70, 80, 90, 95, 100, 110, 120	90-1000mm
3/8" 1/2"	3/8"		8	8 30.3		0.189" 0.177"		50, 60, 70, 80, 90, 95, 100, 110, 120	90-1000mm
3/8" 1/2"	3/8"		9	9 34		0.232" 0.193"		50, 60, 70, 80, 90, 95, 100, 110, 120	90-1000mm
1/2" 3/4"	1/2"		10	10 38		0.200" 0.224"		70, 80, 90, 95, 100, 110, 120	150-1000mm
1/2" 3/4"	1/2"		12	12 45.5		0.252" 0.240"		70, 80, 90, 95, 100, 110, 120	150-1000mm
1/2" 3/4"	1/2"		15	15 56		0.208" 0.280"		70, 80, 90, 95, 100, 110, 120	150-1000mm
1/2" 3/4"	1/2"		17	17 64.4		0.222" 0.332"		70, 80, 90, 95, 100, 110, 120	150-1000mm

Step 1

Choose Body Style
(Block CCB or Round CCR)

Step 2

Determine Flow Rate and Spray Angle
(This determines connection sizes)

Step 3

Determine Nozzle Length
(Increments of 50mm)

Block Version

LIQUID SIZE	MODEL	NOZZLE NO.	SPRAY ANGLE	LENGTH (MM)	MATERIAL
3/8"	CCB	2	90°	200	SS

Round Version

LIQUID SIZE	MODEL	NOZZLE NO.	SPRAY ANGLE	LENGTH (MM)	MATERIAL
3/8"	CCR	2	90°	200	SS

Step 4

Sample Ordering Information

* These dimensions are for reference only and may change as a result of nozzle calibration.

** Angled pipes are also available to suit customer requirements.

Contact our Helpline or your local distributor for further information
Tel: +44 (151) 424 6821 or inside USA Toll Free: 1-800 Delavan
E-mail: delavanspray@goodrich.com or sales@delavan.co.uk

Cool-Cast Nozzle Size: 2 USGPM/7.6 LPM

Liquid Pressure		Air Consumption (SCFM)/Liquid Flow Rate (USGPM) at these Air Pressures (PSI)						Liquid Pressure		Air Consumption (LPM)/Liquid Flow Rate (LPM) at these Air Pressures (BAR)					
PSI	30 PSI		45 PSI		60 PSI		BAR	2.1 BAR		3.1 BAR		4.1 BAR			
	SCFM	USGPM	SCFM	USGPM	SCFM	USGPM		LPM AIR	LPM	LPM AIR	LPM	LPM AIR	LPM		
10	4.5	0.4	5.5	0.3	6.8	0.3	0.7	127	1.6	156	1.3	192	1.2		
20	4.4	0.6	5.5	0.6	6.7	0.5	1.4	125	2.4	155	2.3	190	2		
30	4.2	1	5.4	0.8	6.7	0.7	2.1	118	3.9	153	3.2	189	2.5		
40	4.1	1.1	5.3	1.1	6.6	1	2.8	115	4.3	150	4.2	187	3.6		
50	3.9	1.3	5.2	1.3	6.6	1.2	3.5	110	5	147	4.8	186	4.5		
60	3.7	1.5	5	1.5	6.5	1.4	4.1	104	5.8	142	5.7	185	5.2		
70	3.5	1.8	4.8	1.6	6.3	1.6	4.8	98	6.9	137	6	179	6		
80	3.3	1.9	4.8	1.7	6.2	1.7	5.5	93	7.3	135	6.6	176	6.5		
90	3.1	2.1	4.7	2	6.1	1.8	6.2	87	7.9	132	7.7	173	7		
100	2.9	2.2	4.4	2.1	6	1.9	6.9	82	8.5	125	8.1	170	7.3		

Cool-Cast Nozzle Size: 2.5 USGPM/9.5 LPM

Liquid Pressure		Air Consumption (SCFM)/Liquid Flow Rate (USGPM) at these Air Pressures (PSI)						Liquid Pressure		Air Consumption (LPM)/Liquid Flow Rate (LPM) at these Air Pressures (BAR)					
PSI	30 PSI		45 PSI		60 PSI		BAR	2.1 BAR		3.1 BAR		4.1 BAR			
	SCFM	USGPM	SCFM	USGPM	SCFM	USGPM		LPM AIR	LPM	LPM AIR	LPM	LPM AIR	LPM		
10	4.6	0.3	6.3	0.3	8	0.2	0.7	129	1.2	177	1	227	0.7		
20	4.4	0.7	6.2	0.6	8	0.5	1.4	126	2.8	176	2.3	227	1.9		
30	4.2	1.1	6.1	0.8	7.9	0.7	2.1	120	4	173	3.2	225	2.6		
40	4.1	1.2	5.9	1.1	7.7	1	2.8	115	4.7	166	4.1	219	3.7		
50	3.9	1.6	5.5	1.3	7.6	1.2	3.5	110	5.9	157	5	214	4.5		
60	3.7	1.7	5.3	1.6	7.3	1.4	4.1	104	6.5	150	6	207	5.4		
70	3.4	1.9	5.1	1.7	7	1.6	4.8	96	7.2	144	6.6	200	6.1		
80	3.2	2.1	4.9	1.9	6.8	1.8	5.5	90	7.9	138	7.2	191	6.9		
90	3	2.3	4.6	2.1	6.6	1.9	6.2	86	8.6	131	8	188	7.4		
100	2.8	2.5	4.4	2.4	6.4	2.1	6.9	79	9.4	126	8.9	181	8.1		

Cool-Cast Nozzle Size: 3 USGPM/11.4 LPM

Liquid Pressure		Air Consumption (SCFM)/Liquid Flow Rate (USGPM) at these Air Pressures (PSI)						Liquid Pressure		Air Consumption (LPM)/Liquid Flow Rate (LPM) at these Air Pressures (BAR)					
PSI	30 PSI		45 PSI		60 PSI		BAR	2.1 BAR		3.1 BAR		4.1 BAR			
	SCFM	USGPM	SCFM	USGPM	SCFM	USGPM		LPM AIR	LPM	LPM AIR	LPM	LPM AIR	LPM		
10	5.3	0.5	6.9	0.4	8.8	0.2	0.7	149	2	196	1.5	248	0.9		
20	5	1	6.8	0.8	8.7	0.7	1.4	143	3.7	193	3	247	2.7		
30	4.9	1.4	6.7	1.2	8.7	1	2.1	138	5.3	190	4.5	246	3.7		
40	4.6	1.7	6.6	1.5	8.7	1.4	2.8	131	6.3	186	5.7	245	5.2		
50	4.3	2	6.3	1.8	8.5	1.6	3.5	123	7.7	177	6.8	242	6		
60	4.1	2.3	6	2.1	8.3	1.8	4.1	116	8.6	171	7.9	236	7		
70	3.8	2.6	5.8	2.3	8.1	2.1	4.8	108	9.7	163	8.6	230	8		
80	3.6	2.8	5.5	2.5	7.9	2.4	5.5	102	10.5	157	9.6	224	9		
90	3.3	2.9	5.3	2.8	7.6	2.6	6.2	93	11.1	151	10.6	216	9.7		
100	3.1	3.2	5	2.9	7.3	2.8	6.9	89	12.1	143	11.1	208	10.7		

Cool-Cast Nozzle Size: 4 USGPM/15 LPM

Liquid Pressure		Air Consumption (SCFM)/Liquid Flow Rate (USGPM) at these Air Pressures (PSI)						Liquid Pressure		Air Consumption (LPM)/Liquid Flow Rate (LPM) at these Air Pressures (BAR)					
PSI	30 PSI		45 PSI		60 PSI		BAR	2.1 BAR		3.1 BAR		4.1 BAR			
	SCFM	USGPM	SCFM	USGPM	SCFM	USGPM		LPM AIR	LPM	LPM AIR	LPM	LPM AIR	LPM		
10	7.5	0.7	10.3	0.5	13.4	0.4	0.7	212	2.7	291	1.9	380	1.4		
20	7.2	1.4	10.2	1	13.4	0.8	1.4	204	5.2	290	3.6	379	3.2		
30	6.9	1.8	10.1	1.6	13.3	1.4	2.1	194	6.7	286	5.9	378	5.2		
40	6.5	2.3	9.9	2	13.2	1.8	2.8	183	8.6	279	7.4	375	6.9		
50	6.1	2.6	9.6	2.2	13.1	2.1	3.5	173	9.7	273	8.4	370	7.9		
60	5.8	2.9	9.2	2.7	12.7	2.4	4.1	164	11.1	260	10.2	361	9		
70	5.4	3.3	8.8	3	12.4	2.8	4.8	153	12.4	248	11.5	352	10.5		
80	5.2	3.5	8.5	3.3	12.1	3.1	5.5	147	13.4	242	12.4	342	11.7		
90	5	3.8	8.2	3.5	11.8	3.4	6.2	141	14.5	233	13.3	334	12.9		
100	4.5	4.3	7.8	3.9	11.5	3.7	6.9	127	16.1	222	14.9	326	14.1		

Cool-Cast Nozzles

Cool-Cast Nozzle Size: 5 USGPM/19 LPM

Liquid Pressure	Air Consumption (SCFM)/Liquid Flow Rate (USGPM) at these Air Pressures (PSI)					
	30 PSI		45 PSI		60 PSI	
	SCFM	USGPM	SCFM	USGPM	SCFM	USGPM
10	8.9	0.9	11.9	0.7	15.9	0.4
20	8.7	1.6	11.9	1.3	15.8	1.2
30	8.3	2.1	11.8	1.8	15.8	1.7
40	7.8	2.6	11.5	2.3	15.7	2.0
50	7.5	3.2	11.2	2.8	15.6	2.6
60	7.1	3.6	10.8	3.2	15.2	3
70	6.7	4	10.5	3.7	15	3.4
80	6.5	4.4	10.1	4	14.7	3.8
90	6	4.7	9.7	4.4	14.5	4
100	5.7	5.1	9.4	5	14.1	4.4

Liquid Pressure	Air Consumption (LPM)/Liquid Flow Rate (LPM) at these Air Pressures (BAR)					
	2.1 BAR		3.1 BAR		4.1 BAR	
	LPM AIR	LPM	LPM AIR	LPM	LPM AIR	LPM
0.7	252	3.3	338	2.5	449	1.7
1.4	246	5.9	337	5	448	4.4
2.1	236	7.9	334	6.9	447	6.3
2.8	222	10	326	8.6	445	7.7
3.5	213	12	316	10.5	441	9.7
4.1	200	13.8	305	12.3	430	11.4
4.8	190	15	296	14	424	12.7
5.5	183	16.5	285	15.1	417	14.4
6.2	170	17.7	275	16.5	411	15.3
6.9	162	19.3	267	18.9	400	16.7

Cool-Cast Nozzle Size: 6.5 USGPM/24.6 LPM

Liquid Pressure	Air Consumption (SCFM)/Liquid Flow Rate (USGPM) at these Air Pressures (PSI)					
	30 PSI		45 PSI		60 PSI	
	SCFM	USGPM	SCFM	USGPM	SCFM	USGPM
10	15	0.7	20.9	0.4	26.1	0.3
20	14.3	1.7	20.8	1.2	25.8	0.9
30	13.4	2.4	20.6	1.8	25.5	1.8
40	11.9	3.3	19.8	2.7	25.1	2.3
50	11.5	4	18.5	3.2	24.5	2.9
60	11	4.9	16.8	4.1	23.7	3.5
70	10.9	5.6	16.1	4.9	22.7	4.1
80	10.5	6.1	15.1	5.7	21.2	4.8
90	10.5	6.7	14.6	6.2	20.7	5.6
100	10.4	7.3	13.4	6.5	19.7	6.2

Liquid Pressure	Air Consumption (LPM)/Liquid Flow Rate (LPM) at these Air Pressures (BAR)					
	2.1 BAR		3.1 BAR		4.1 BAR	
	LPM AIR	LPM	LPM AIR	LPM	LPM AIR	LPM
0.7	425	2.6	592	1.4	738	1
1.4	405	6.4	588	4.6	732	3.5
2.1	380	9.2	583	7	723	6.8
2.8	337	12.4	560	10.2	712	8.7
3.5	327	15.1	525	12.1	693	11
4.1	312	18.4	475	15.4	670	13.4
4.8	308	21.1	457	18.4	642	15.6
5.5	298	23.2	427	21.4	602	18
6.2	297	25.5	413	23.4	587	21.1
6.9	293	27.6	380	24.5	557	23.5

Cool-Cast Nozzle Size: 8 USGPM/30.3 LPM

Liquid Pressure	Air Consumption (SCFM)/Liquid Flow Rate (USGPM) at these Air Pressures (PSI)					
	30 PSI		45 PSI		60 PSI	
	SCFM	USGPM	SCFM	USGPM	SCFM	USGPM
10	16	0.6	22	0.4	27.3	0.1
20	14.6	1.8	21.4	1.2	27.2	0.9
30	12.6	2.6	20.5	1.9	26.7	1.5
40	12.1	3.7	18.8	2.8	25.7	2.2
50	11.1	4.6	16.5	3.5	24.7	2.9
60	11	5.2	14.7	4.4	22.6	3.7
70	10.5	6.1	13.4	5.3	21.4	4.9
80	9.5	7.1	12.1	6.5	19.9	5.3
90	7.9	7.9	11.4	7.3	18.1	6.3
100	6.5	8.6	10.8	7.9	16.9	6.7

Liquid Pressure	Air Consumption (LPM)/Liquid Flow Rate (LPM) at these Air Pressures (BAR)					
	2.1 BAR		3.1 BAR		4.1 BAR	
	LPM AIR	LPM	LPM AIR	LPM	LPM AIR	LPM
0.7	453	2.5	622	1.7	773	0.5
1.4	413	6.7	607	4.4	770	3.2
2.1	357	9.9	580	7	755	5.7
2.8	343	14.2	532	10.5	727	8.5
3.5	313	17.4	467	13.4	700	11.2
4.1	312	19.6	415	16.8	640	14
4.8	297	23	380	20.1	605	18.5
5.5	270	27	342	24.7	563	20.2
6.2	223	30	322	27.7	513	23.8
6.9	183	32.4	307	29.9	478	25.3

Cool-Cast Nozzle Size: 9 USGPM/34 LPM

Liquid Pressure	Air Consumption (SCFM)/Liquid Flow Rate (USGPM) at these Air Pressures (PSI)					
	30 PSI		45 PSI		60 PSI	
	SCFM	USGPM	SCFM	USGPM	SCFM	USGPM
10	21.2	0.8	32.4	0.5	43	0.4
20	19.6	1.8	31.8	1	42	0.8
30	16.2	3.1	30.5	1.9	41.1	1.3
40	14.1	4	26.7	3	40.5	2.2
50	12.3	5.7	24.1	4	37.6	3.1
60	10.9	6.4	20.6	5.3	34.8	3.9
70	10.8	7.4	18.5	6.3	31.3	5.2
80	10.7	8.4	16.4	7.1	29	6.1
90	10	9.1	15.2	8.2	26.5	7
100	9.5	9.8	13.8	8.9	24.5	7.7

Liquid Pressure	Air Consumption (LPM)/Liquid Flow Rate (LPM) at these Air Pressures (BAR)					
	2.1 BAR		3.1 BAR		4.1 BAR	
	LPM AIR	LPM	LPM AIR	LPM	LPM AIR	LPM
0.7	600	2.9	917	2	1217	1.5
1.4	555	6.7	900	3.9	1189	2.9
2.1	458	11.9	864	7.1	1165	5
2.8	400	15.2	755	11.4	1147	8.3
3.5	348	21.5	682	15.2	1065	11.8
4.1	310	24.2	583	20	985	14.9
4.8	305	28.1	525	23.7	885	19.8
5.5	302	31.7	463	27	820	23.1
6.2	283	34.4	430	30.9	750	26.5
6.9	268	37	390	33.8	695	29

Cool-Cast Nozzle Size: 10 USGPM/38 LPM

Liquid Pressure		Air Consumption (SCFM)/Liquid Flow Rate (USGPM) at these Air Pressures (PSI)						Liquid Pressure		Air Consumption (LPM)/Liquid Flow Rate (LPM) at these Air Pressures (BAR)					
PSI	30 PSI		45 PSI		60 PSI		BAR	2.1 BAR		3.1 BAR		4.1 BAR			
	SCFM	USGPM	SCFM	USGPM	SCFM	USGPM		LPM AIR	LPM	LPM AIR	LPM	LPM AIR	LPM		
10	16.2	2.2	21.8	1.8	27.5	1.6	0.7	460	8.5	617	6.9	779	6.1		
20	15.8	3.7	21.4	3.1	27.3	2.9	1.4	447	14	605	11.7	773	10.8		
30	15.4	4.4	21.2	4.2	27	3.7	2.1	437	16.8	602	15.8	765	14		
40	15.1	5.1	21.1	5	26.9	4.7	2.8	427	19.4	598	18.8	762	17.9		
50	14.8	5.9	21.1	5.8	26.8	5.5	3.5	418	22.4	597	21.9	759	20.8		
60	14.4	7.1	21	6.9	26.7	6.4	4.1	408	26.8	593	26.2	756	24.1		
70	14.1	7.8	20.8	7.8	26.5	7.3	4.8	400	29.7	588	29.5	750	27.5		
80	13.8	8.9	20.7	8.4	26.4	7.8	5.5	390	33.7	585	31.9	748	29.7		
90	13.4	9.4	20.5	9	26	8.6	6.2	378	35.7	582	34.2	736	32.7		
100	13	10	20.4	9.9	25.4	9.2	6.9	368	37.9	578	37.6	719	35		

Cool-Cast Nozzle Size: 12 USGPM/45.6 LPM

Liquid Pressure		Air Consumption (SCFM)/Liquid Flow Rate (USGPM) at these Air Pressures (PSI)						Liquid Pressure		Air Consumption (LPM)/Liquid Flow Rate (LPM) at these Air Pressures (BAR)					
PSI	30 PSI		45 PSI		60 PSI		BAR	2.1 BAR		3.1 BAR		4.1 BAR			
	SCFM	USGPM	SCFM	USGPM	SCFM	USGPM		LPM AIR	LPM	LPM AIR	LPM	LPM AIR	LPM		
10	17.5	2.6	25.7	2.3	33.7	2.1	0.7	495	9.7	728	8.7	954	8.1		
20	17.2	4.3	25.4	4.2	33.5	3.6	1.4	488	16.2	720	16	950	13.4		
30	17	5.5	25.3	5	33.4	4.6	2.1	480	21	717	18.9	947	17.6		
40	16.7	6.6	25.2	6.3	33.4	5.4	2.8	478	25	713	23.7	947	20.5		
50	16.2	7.5	25	7	33.3	6.8	3.5	460	28.3	707	26.6	942	25.6		
60	15.7	9	24.6	8.4	33.1	7.6	4.1	443	34.3	697	31.8	939	28.7		
70	14.4	10.3	24.4	9.5	32.8	9	4.8	407	39.1	692	36	929	34.2		
80	14.1	10.7	23.3	10.4	32.5	10	5.5	400	40.4	660	39.4	920	37.8		
90	14	11.6	23.1	11.1	32	10.8	6.2	397	43.8	653	42.2	905	40.8		
100	13.7	12.2	22.2	12	31.8	11.6	6.9	388	46.2	630	45.4	900	43.9		

Cool-Cast Nozzle Size: 15 USGPM/56 LPM

Liquid Pressure		Air Consumption (SCFM)/Liquid Flow Rate (USGPM) at these Air Pressures (PSI)						Liquid Pressure		Air Consumption (LPM)/Liquid Flow Rate (LPM) at these Air Pressures (BAR)					
PSI	30 PSI		45 PSI		60 PSI		BAR	2.1 BAR		3.1 BAR		4.1 BAR			
	SCFM	USGPM	SCFM	USGPM	SCFM	USGPM		LPM AIR	LPM	LPM AIR	LPM	LPM AIR	LPM		
10	20.5	4.1	27.8	3.6	35.9	3.2	0.7	580	15.5	787	13.6	1017	12.1		
20	20.3	6.1	27.4	5.7	35.8	5.3	1.4	575	23.2	777	21.4	1014	20		
30	20.2	7.7	27.4	7.2	35.7	6.8	2.1	572	29.1	775	27.3	1010	25.9		
40	19.4	9.1	27.3	8.5	35.3	8.2	2.8	548	34.5	772	32.3	1000	30.9		
50	19	10.3	26.9	9.9	35.3	9.4	3.5	538	39.1	762	37.3	999	35.5		
60	18.8	11.5	26.7	10.8	35.1	10.4	4.1	533	43.6	757	40.9	995	39.5		
70	17.9	12.6	26.5	11.9	35	11.5	4.8	507	47.7	750	45	990	43.4		
80	17.3	13.7	26.2	13	34.6	12.5	5.5	490	51.8	742	49.1	980	47.3		
90	17	14.7	25.4	13.9	34.5	13.5	6.2	480	55.5	720	52.7	979	51.1		
100	16.7	15.5	25.2	14.9	34.4	14.4	6.9	472	58.6	715	56.4	975	54.6		

Cool-Cast Nozzle Size: 17 USGPM/64.4 LPM

Liquid Pressure		Air Consumption (SCFM)/Liquid Flow Rate (USGPM) at these Air Pressures (PSI)						Liquid Pressure		Air Consumption (LPM)/Liquid Flow Rate (LPM) at these Air Pressures (BAR)					
PSI	30 PSI		45 PSI		60 PSI		BAR	2.1 BAR		3.1 BAR		4.1 BAR			
	SCFM	USGPM	SCFM	USGPM	SCFM	USGPM		LPM AIR	LPM	LPM AIR	LPM	LPM AIR	LPM		
10	24.2	4.3	32.1	3.7	40.4	3.3	0.7	685	16.3	909	14	1145	12.5		
20	23.5	6.6	32	6	40.4	5.5	1.4	667	24.9	907	22.7	1144	20.8		
30	23.5	8.4	32	7.8	40.3	7.3	2.1	665	31.8	905	29.5	1142	27.6		
40	23	10	31.6	9.4	40	8.9	2.8	650	37.9	895	35.6	1134	33.6		
50	22.2	11.4	31.5	10.7	40	10.2	3.5	628	43.1	894	40.5	1132	38.6		
60	21.2	12.7	31.3	12	39.9	11.6	4.1	600	48.1	885	45.4	1130	43.9		
70	20.2	14	30.6	13.2	39.8	12.7	4.8	572	53	867	49.9	1129	48.1		
80	18.8	15.2	30.4	14.3	39.4	13.9	5.5	533	57.5	862	54.1	1117	52.6		
90	18.4	16.3	30	15.4	39	14.9	6.2	520	61.7	850	58.3	1104	56.4		
100	17.1	17.2	29.7	16.5	38.4	15.9	6.9	483	65.1	840	62.5	1087	60.2		

Cool-Cast Nozzles

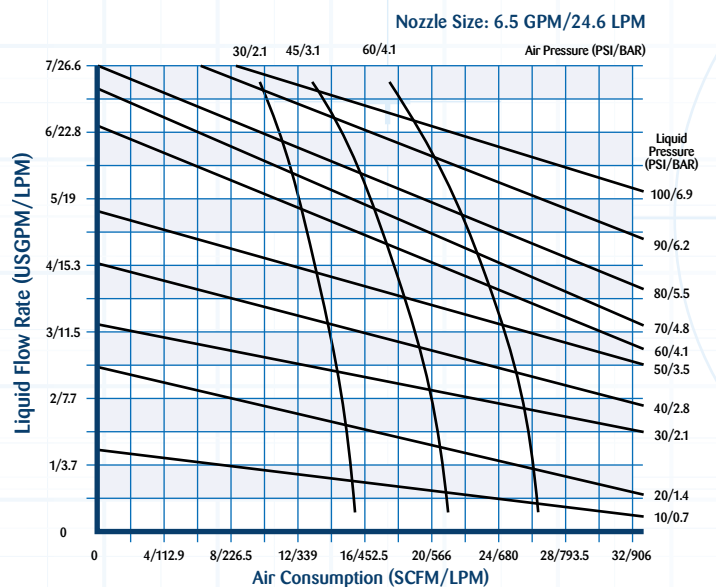
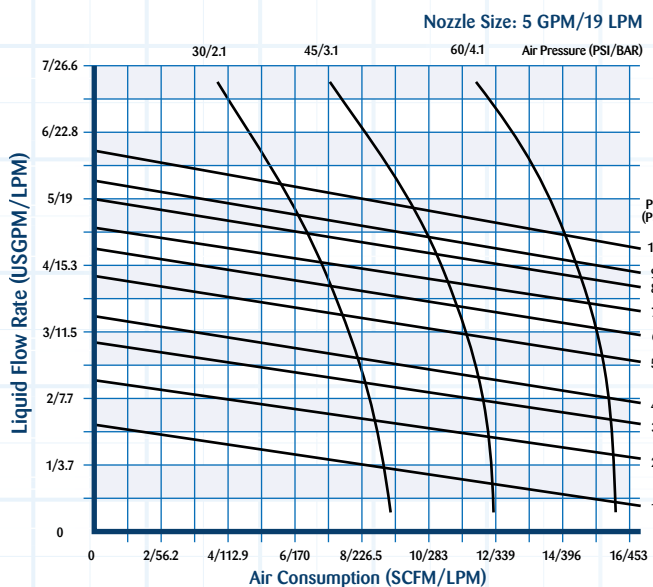
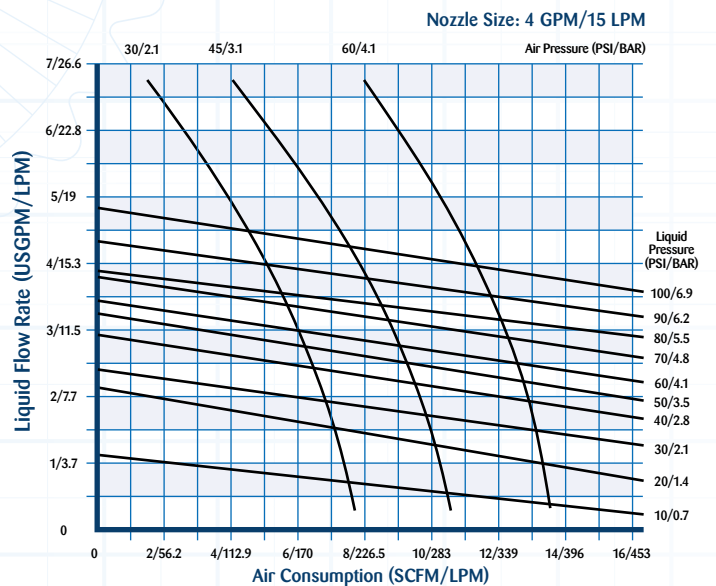
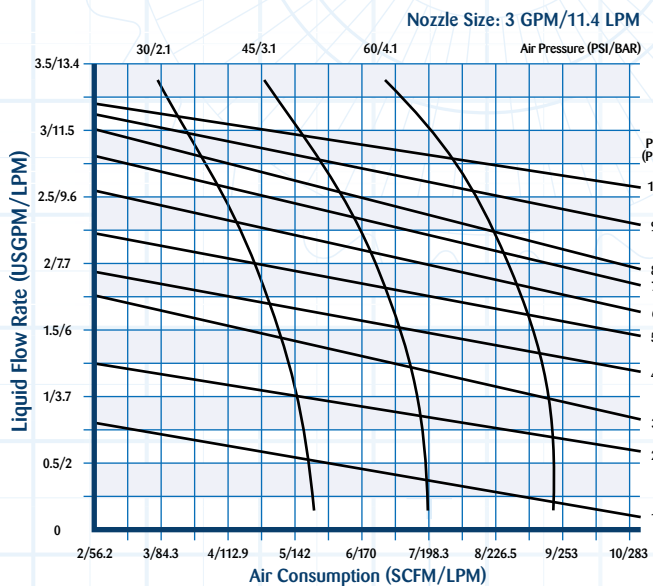
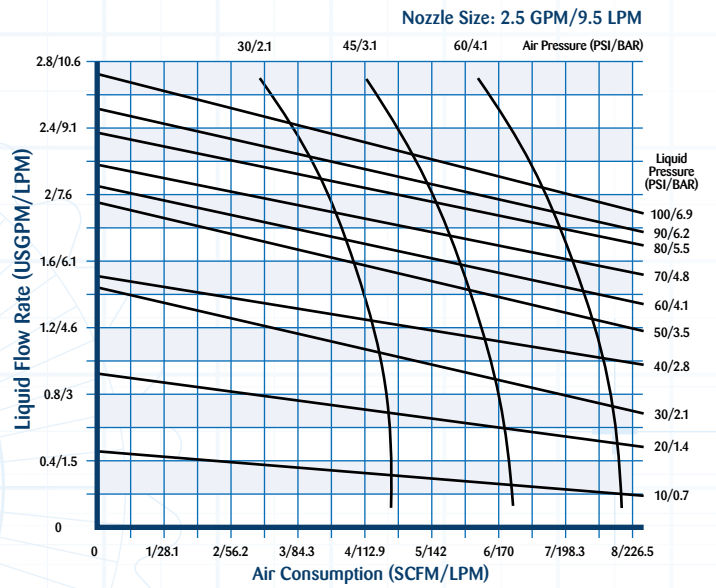
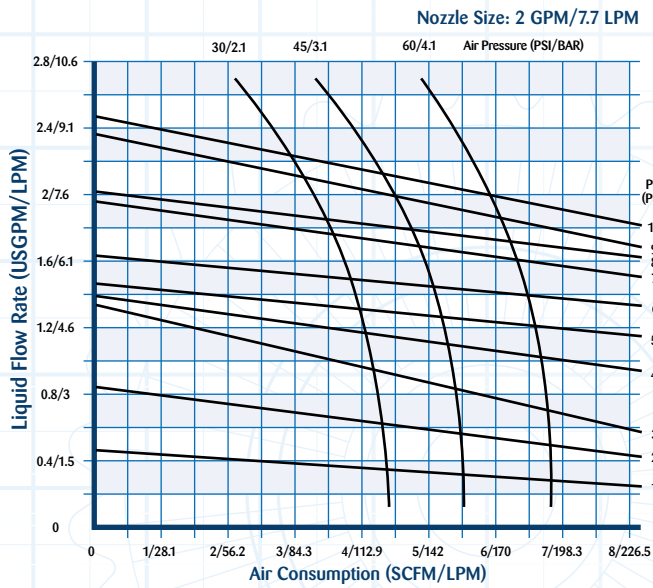

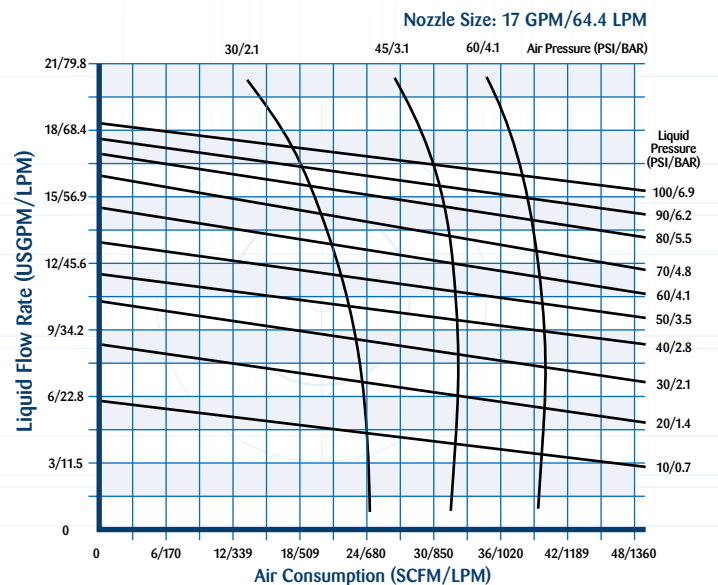
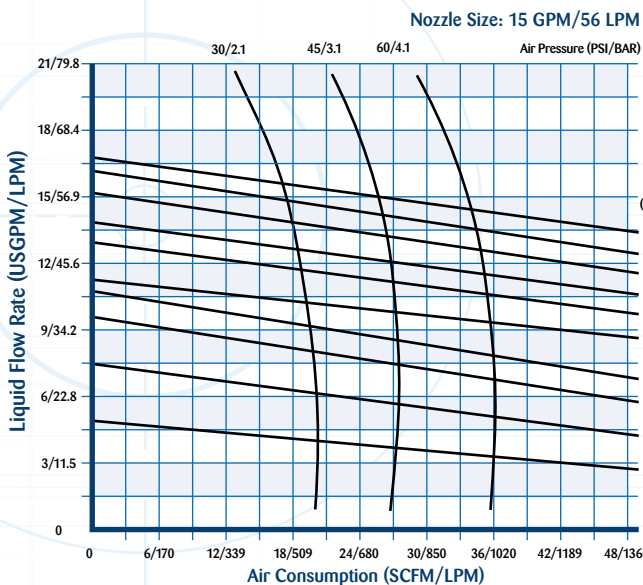
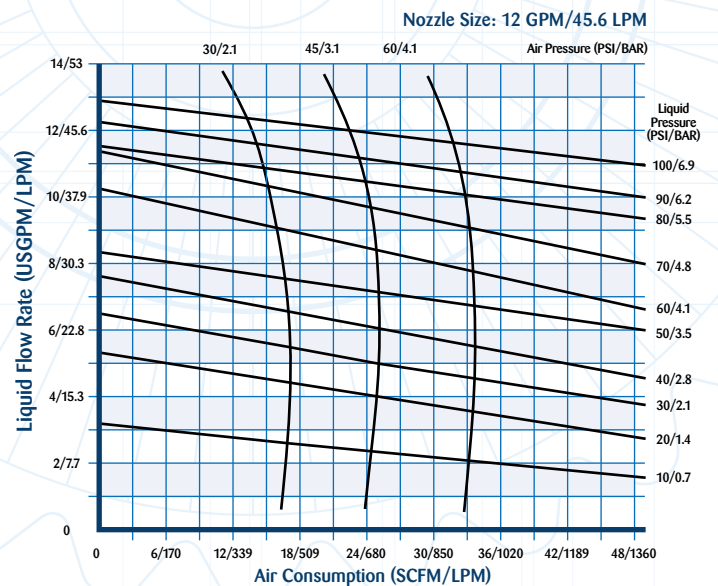
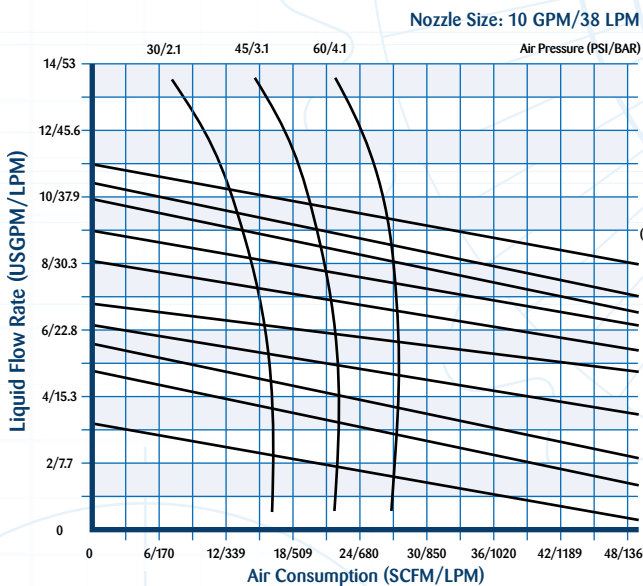
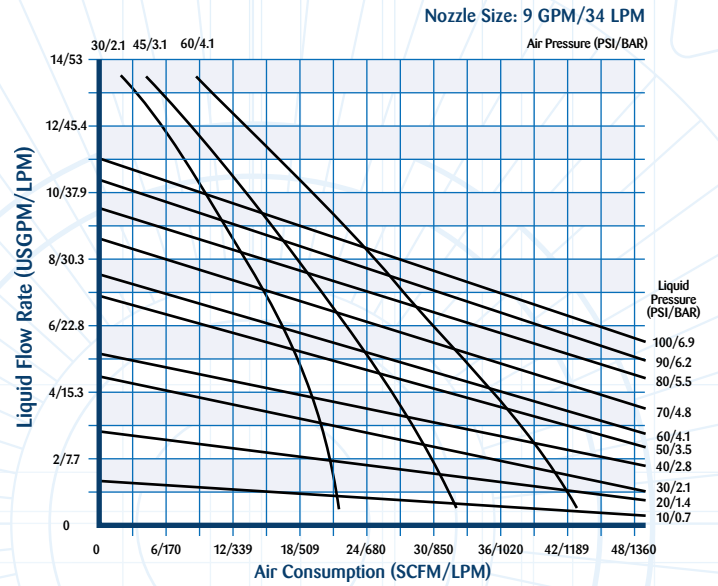
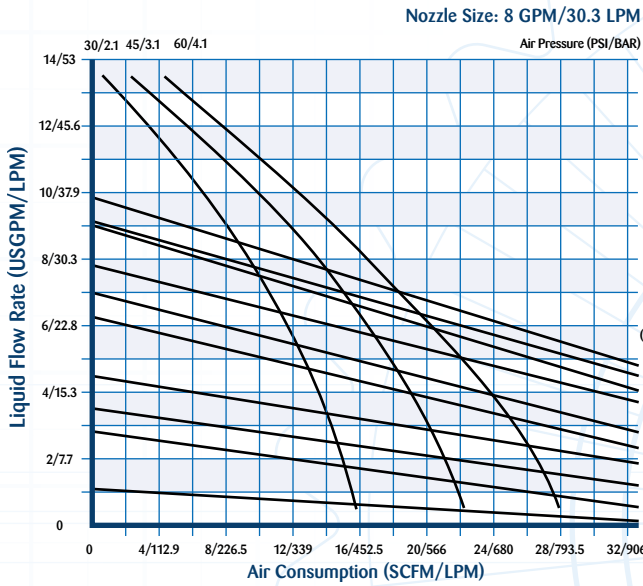



Other Delavan nozzles used in Continuous Casting:

Flat Spray – AC, LF, LD, AD, LE

Solid Cone Spray – BI, BN, BQ, BT, BC

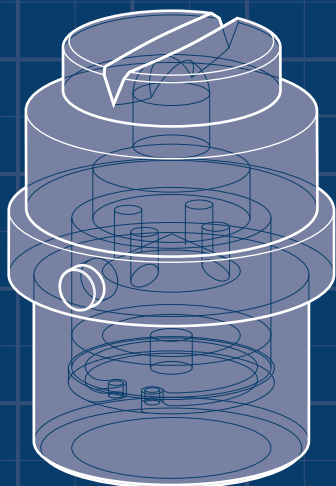

The Delavan RLD Flat Spray Nozzle has been designed for use in Hydraulic Continuous Casting Machines. The internal design of the nozzle provides a thicker spray footprint, thus resulting in an increased cooling efficiency over a standard flat spray nozzle.

The nozzle also includes a built in location fitting to eliminate incorrect alignment. Flow rates are available from 4-18 LPM (1-4.8 USGPM) at 2.8 BAR (40 PSI) with a spray angle of 80°.

For more information contact the Delavan Sales Team.

Details of all our products are available on our website at www.delavan.com

Delavan Ltd, Gorse Lane, Widnes, Cheshire WA8 ORJ, UK
Telephone: +44 (0)151 424 6821 Fax: +44 (0)151 495 1043
Inside USA Toll Free: 1-800 Delavan
e-mail: sales@delavan.co.uk or delavanspray@goodrich.com

Delavan and the Goodrich Stripes logo are registered trademarks of Delavan Spray Technologies and the Goodrich Corporation respectively ©Delavan Spray Technologies 2008.
All materials are the intellectual property of Goodrich and cannot be used without Goodrich's consent.

BROCHURE VERSION 2.0 2008

An ISO 9001:2000 Registered Company

